

51V 100Ah FLATPACK BATTERY MODULE

GTO SERIES

CAT # GTO51V100A-E1914



Battery Details

100Ah at 51.2V
5,120 Watt-Hours

Key Benefits

- ✓ Safe, Non-Toxic Lithium Iron Phosphate Cells
- ✓ NeverDie® Battery Management System Maximizes Lifespan
- ✓ Fire and Crush Tested Aluminum Alloy Enclosure

Reliable Power, Unmatched Versatility

Our battery system features easy expandability for extended run times and delivers dependable performance, even in extreme temperatures.

DIMENSIONS

Size (L x W x H):

19.0" x 14.5" x 6.6"
(482.6 x 368.3 x 167.6)

Weight:

93lbs
(42.2kg)

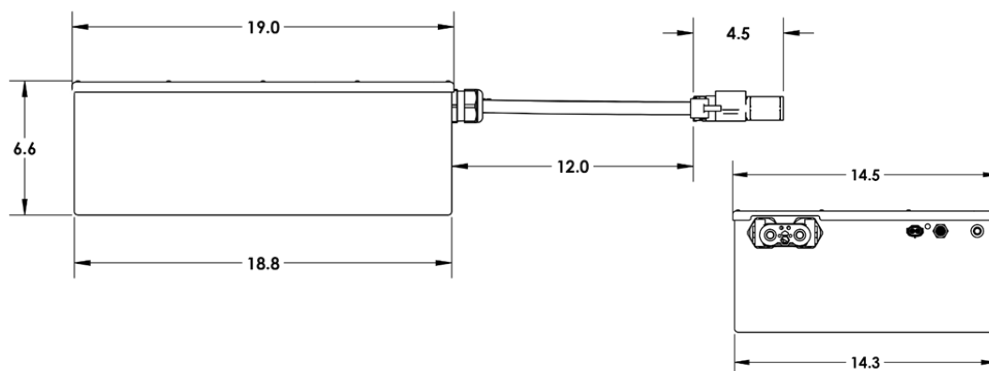

SPECIFICATIONS

VOLTAGE AND CAPACITY

51.2V 100Ah 5,120Wh

SHIPPING

UN3480, Class 9

CERTIFICATIONS

UN38.3, UL 1642

INTERNAL HEATER

70W Power Rating
12V Nominal Input Voltage
5.8A Input Current
Thermostat Activation and Deactivation (Internal) <43°F (6°C) On, >48°F (9°C) Off

STORAGE

Refer to the Lithionics® Website for the Storage Procedure

APPLICATION NOTE: EXTERNAL BMS REQUIRED. BMS SOLD SEPARATELY.

ELECTRICAL

<6mΩ Resistance
99% Coulombic Efficiency
<3% Self-Discharge Rate (per month)
Prismatic, LiFePO₄ Cells
Power Connection:
Anderson A320 Female

DISCHARGE

46.4V to 57.6V ±0.8V
-22 to 140°F (-30 to 60°C)
<205A Recommended Discharge Current
<100A Discharge Current
<1,000A Pulse Current (1 second)
46.4V ±0.8V Cut-Off Voltage

*Charging and discharging rates vary with temperature and usage

MECHANICAL

Mounting Orientation: Upright position only (black lid up)
Aluminum 5052.090" Enclosure
Military Grade Corrosion Protection Enclosure
Ingress Protection: IP66

CHARGE

57.6V ±0.8V
32°F to 140°F (0 to 60°C)
-4°F (-20°C) with Heater Power Connected
<50A Recommended Charge Current
54.4V ±0.8V Float Voltage
<100A Charge Current

Powering Innovation.

Discover the right lithium replacement system for you. Reach out to Lithionics' expert support team to find your perfect power solution.

BMS Advanced Features

- External Battery Management System (BMS) for enhanced safety and monitoring
- Bluetooth connectivity for real-time diagnostics
- State-of-Charge (SoC) monitoring to prevent unexpected shutdowns
- High current capability up to 400A for versatile applications
- Remote monitoring app (Google Play and Apple App Store)



CAT # NDV9