

DUAL CHANNEL

Advanced Battery Management System

CAT # NDV9



Voltage Options

12V	NDV9-12V-DUAL
24V	NDV9-24V-DUAL
48V	NDV9-48V-DUAL
51V	NDV9-51V-DUAL
102V	NDV9-102V-DUAL

Key Benefits

- ✓ Advanced iONbus® Technology
- ✓ NeverDie® Power Reserve
- ✓ Suitable for Various Applications, Dual Channel allows for separate charge and discharge channels

Reliable Power, Seamless Integration

Experience peace of mind with Lithionics Bluetooth app for real-time monitoring and diagnostics. Optimize your battery usage utilizing our innovative Battery Management System (BMS) that provides advanced protection ensuring battery safety and longevity. Easily connect multiple batteries to a single BMS by plugging directly into a combiner box.

DIMENSIONS

Size (L x W x H):

13.0" x 23.7" x 4.0"
(330.2mm x 602.0mm x 101.6mm)

Weight:

8.0 lbs
(3.6kg)

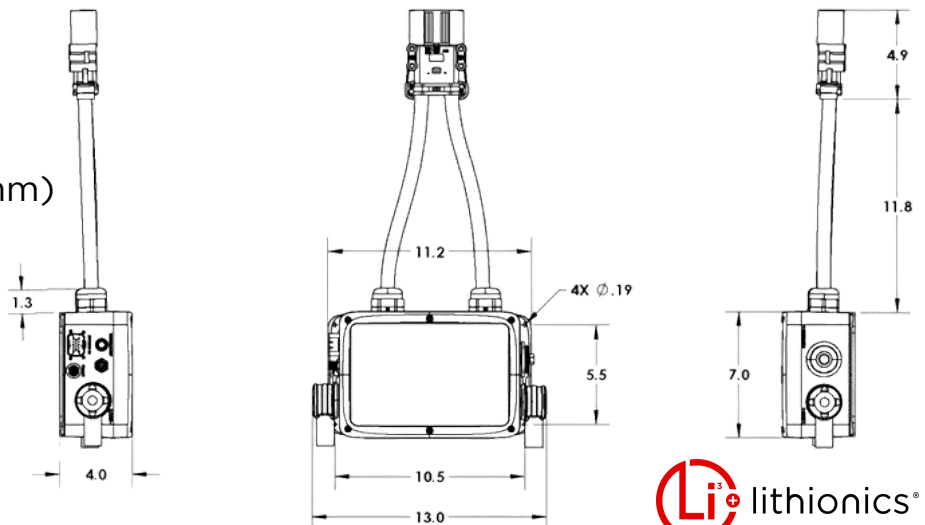

SPECIFICATIONS

VOLTAGE AND CAPACITY

12.8V to 102.4V (4S-32S)
400A* Amperage Continuous

*325A continuous with a single 4/0 Wire,
400A continuous requires 350MCM or 2x4/0
cables connected to each of the BMS terminals for
heat dissipation

AMPSEAL-14 Functions (Support depends on specific AMPSEAL-14 wire harness):

FCC Alternator Control, Generator Control, Remote
Lighted ON/OFF, Alarm Battery Low LED,
Emergency- Stop, RS232, Aux. External Power Input

Bluetooth®:

Includes App (iOS, Android). Monitoring,
Datalogging, Firmware Updates, PIN Security

FEATURES

Protection Features:

Reserve Cut-Off, Pack Over and Under Voltage, Cell
Over and Under Voltage, Cell Over and Under
Temperature, Contactor Over-Temperature, Contactor
State, Short Circuit, Over Current, Pre-charge circuit

Optional Features:

RS232 (In place of Bluetooth), Ethernet TCP/IP, NMEA
2000 Port

Easily Integrates With:

NCC CANbus Chargers, IonGauge Display, Victron
Cerbo Support, Wakespeed WS500 Alternator
Regulator, RV-C CANbus Compliant Devices, NMEA
2000 Compliant Devices, SmartPower Alternator
Series, Lithionics 3,000W Inverter-Charger

MECHANICAL

Terminal Size: 5/16-18

Terminal Torque: 108-132in-lbs (12.2-14.9Nm)

Ingress Protection: IP 66

iONbus (M12 Connector):

Combines OptoLoop and RV-C CANbus
technology into one connector

Included Components:

IonBus T-Adapter, 2 IonBus Terminators,
Terminal Covers



DS-019

Powering Innovation.

Discover the right lithium
replacement system for you.
Reach out to Lithionics'
expert support team to find
your perfect power solution.